



COMPACT BALL VALVE

CC100 SOCKET/ CC200 THREAD
Size:DN8~DN150



ISO 9001



CCSeries

Compact Ball Valves Torque Value

SIZE	Torque Value(kgf/cm)			
	EPDM-SEAT		PTFE -SEAT	
	OPEN	CLOSE	OPEN	CLOSE
1/2"	12-22	12-22	10-20	20-30
3/4"	20-30	30-40	20-30	25-35
1"	26-36	43-53	30-40	30-40
1-1/4" *	44-59	44-59	50-65	70-85
1-1/2"	50-65	60-75	47-62	60-75
2"	50-70	100-120	60-80	120-140
2-1/2"	80-100	70-90	-	-
3"	140-160	130-150	-	-
4"	160-180	150-170	-	-

1kgf/cm = 0.098 N.m

MATERIALS OF CONSTRUCTION

Item	Parts	Pcs	Materials	Item	Parts	Pcs	Materials
1	Stem	1	UPVC, CPVC	5	Cap	2	ABS
2	Ball	1	UPVC, CPVC	6	Handle	1	ABS
3	Body	1	UPVC, CPVC	7	Seat	2	EPDM,PTFE
4	Stem O'ring	1	EPDM				

COMPACT BALL VALVE



ISO 9001

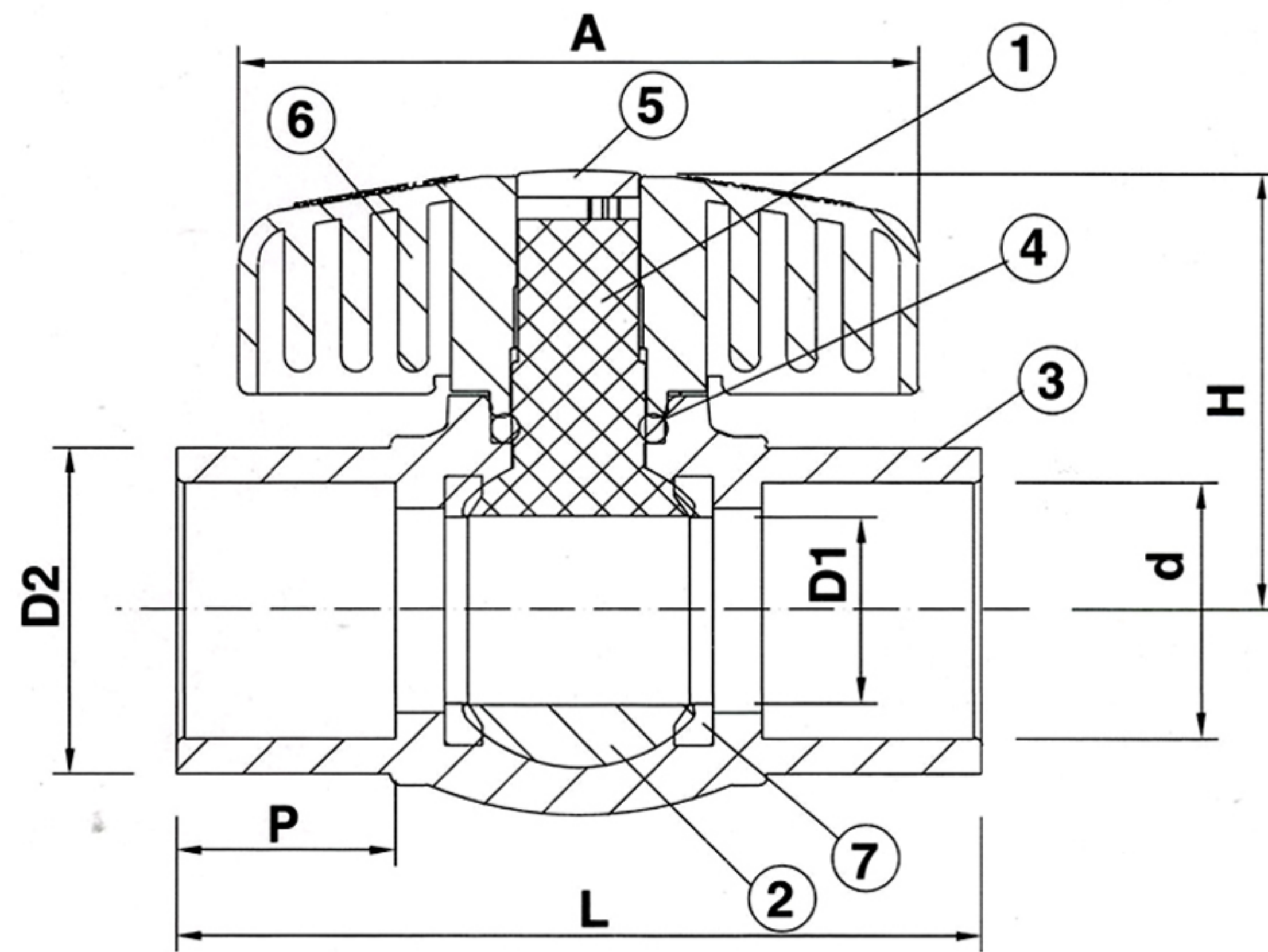

DN15~DN50

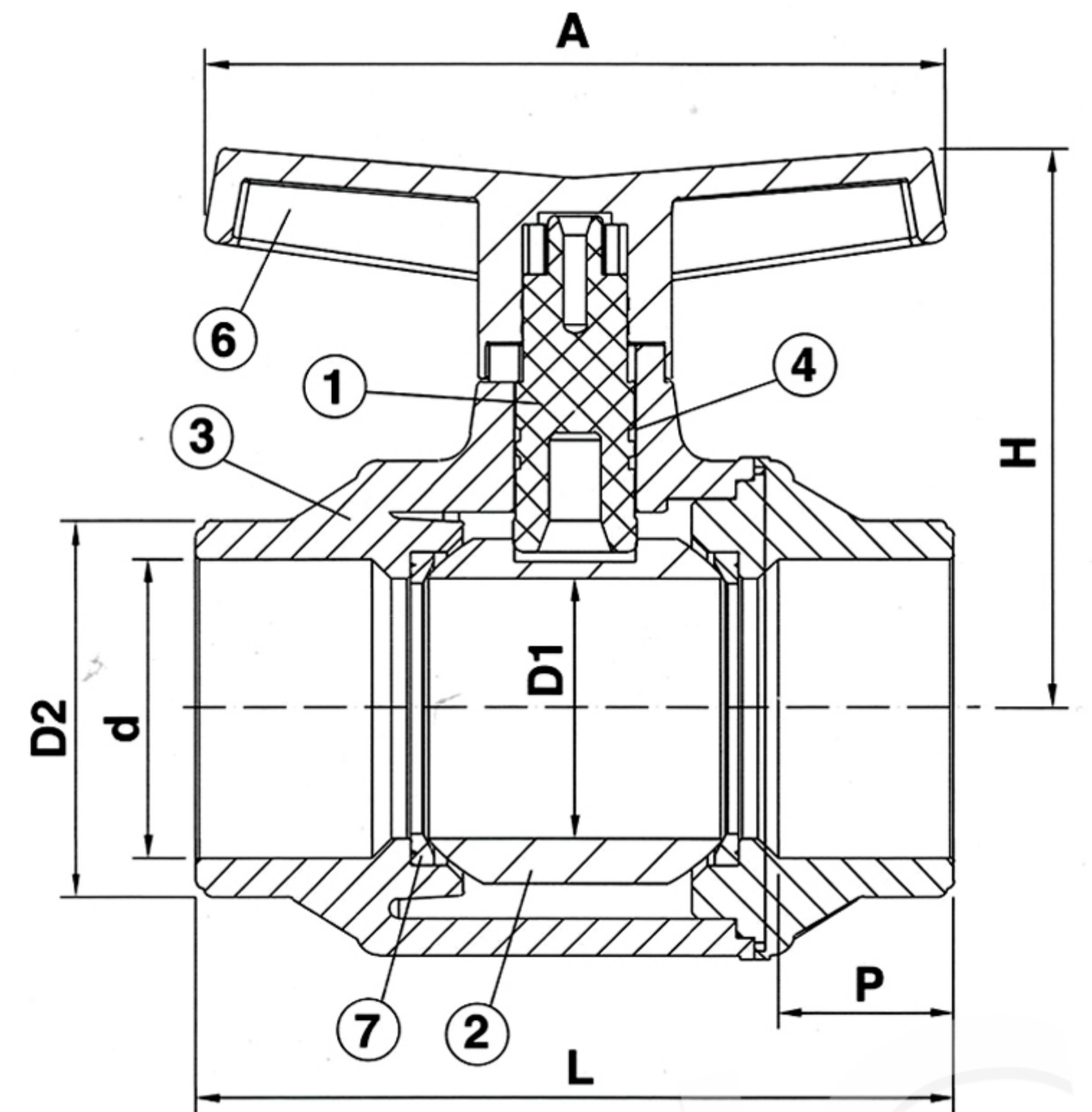

DN65~DN150

DIMENSIONS TABLE

Standards	JIS									ANSI									DIN								
	Unit:mm									Unit:inch									Unit:mm								
	Nom.Size DN-inch	d		P	L	D2	H	A	Test Press. (kgf/cm ²)	D1	d		P	L	D2	H	A	Test Press. (lb/in ²)	D1	d		P	L	D2	H	A	Test Press. (kgf/cm ²)
Socket		Thread	Socket								Thread	Socket								Thread	Socket						
15-1/2"	15	22	PT1/2	22.2	79	29	47	70	15	0.591	0.840	NPT1/2	0.875	3.110	1.141	1.850	2.756	222	15	20	R1/2	16.0	79	29	47	70	15
20-3/4"	20	26	PT 3/4	25.4	90.5	36.5	57	77	15	0.787	1.050	NPT3/4	1.000	3.562	1.427	2.244	3.031	222	20	25	R3/4	18.5	90.5	36.5	57	77	15
25-1"	25	32	PT1	28.6	106.5	43	61	89	15	0.984	1.315	NPT1	1.125	4.173	1.627	2.402	3.504	222	25	32	R1	22.0	106.5	43	61	89	15
32-1-1/4"	32	38	PT1-1/4	31.8	123	53	66	89	15	1.260	1.660	NPT1-1/4	1.250	4.842	2.086	2.598	3.504	222	32	40	R1-1/4	26.0	123	53	66	89	15
40-1-1/2"	39	48	PR1-1/2	34.9	129	61	74	111	15	1.535	1.900	NPT1-1/2	1.375	5.098	2.401	2.913	4.370	222	39	50	R1-1/2	31.0	129	61	74	111	15
50-2"	50	60	PT2	38.1	150.5	73	80	139	15	1.969	2.375	NPT2	1.500	5.925	2.874	3.150	5.472	222	50	63	R2	37.5	150.5	73	80	139	15
*65-2-1/2"	66	76	PT2-1/2	44.5	194	96	141	190	10	2.598	2.875	NPT2-1/2	1.750	7.638	3.780	5.550	7.48	148	66	75	R2-1/2	43.5	194	96	141	190	10
*80-3"	78	89	PT3	47.6	233	110	154	230	10	3.071	3.500	NPT3	1.875	9.173	4.331	6.063	9.005	148	78	90	R3	51.0	233	110	154	230	10
*100-4"	100	114	PT4	57.6	280	136	170	274	10	3.94	4.500	NPT4	2.250	11.00	5.35	6.7	10.79	148	100	110	R4	61.0	280	136	170	274	10
*125-5"	99	140	PT5	60.6	264	159	174	235	7	3.897	5.583	NPT5	3.000	10.393	6.260	6.870	9.215	100	99	125	R5	70	264	159	174	235	7
*150-6"	130	166	PT6	90	376	195.6	182	323	7	5.118	6.647	NPT6	3.541	14.794	7.696	7.161	12.72	100	130	160.2	R6	90	376	195.6	182	323	7